

- $V_{CE}=650V$
- $I_C=75A@T_C=100$
- $V_{CE(sat)}=1.7V$

TO-247i

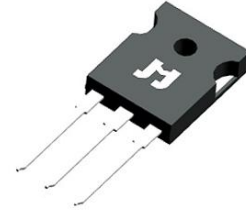

- Trench and field-stop technology.
- Easy parallel switching capability.

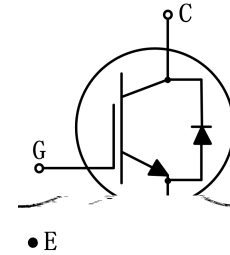

- High efficiency for inverters.
- High ruggedness performance.
- RoHS compliant.

- PFC applications
- Uninterruptible power supplies
- Solar inverters

Type	Marking	Package	Packaging Method
JJT75N65UK	T7565UK	TO-247i (内绝缘)	Tube



V_{CES}	Collector-emitter voltage	650	V
V_{GES}	Gate-emitter voltage	± 20	V
	Transient gate-emitter voltage(t_p 10 μ s, $D < 0.010$)	± 30	V
I_C	Continuous collector current ($T_C=25$)	150	A
	Continuous collector current ($T_C=100$)	75	A
I_{CM}	Pulsed collector current, t_p limited by T_{vjmax}	300	A
I_F	Diode continuous forward current ($T_C=100$)	75	A
I_{FM}	Diode maximum current, t_p limited by T_{vjmax}	300	A
P_{tot}	Power dissipation ($T_C=25$)	535	W
	Power dissipation ($T_C=100$)	267	W
T_{vj}	Operating junction temperature range	-40 to +175	
T_{stg}	Storage temperature range	-55 to +175	

$R_{th(j-c)}$ Thermal resistance, junction to case for IGBT - 0.35 K/W

$R_{th(j-c)}$ Thermal resistance, jun



($T_{vj}=25^{\circ}\text{C}$ unless otherwise specified)

Static characteristics

BV_{CES}	Collector-emitter breakdown voltage	$V_{GE}=0\text{V}, I_C=250\mu\text{A}$	650	-	-	V
I_{CES}	Collector-emitter leakage current	$V_{CE}=650\text{V}, V_{GE}=0\text{V}$	-	-	50	μA
I_{GES}	Gate leakage current, forward	$V_{GE}=20\text{V}, V_{CE}=0\text{V}$	-	-	100	nA
	Gate leakage current, reverse	$V_{GE}=-20\text{V}, V_{CE}=0\text{V}$	-	-	-100	nA
$V_{GE(th)}$	Gate-emitter threshold voltage	$V_{GE}=V_{CE}, I_C=1\text{mA}$	4.7	5.2	5.7	V
$V_{CE(sat)}$	Collector-emitter saturation voltage	$V_{GE}=15\text{V}, I_C=75\text{A}$	1.60	1.72	1.90	V
		$V_{GE}=15\text{V}, I_C=75\text{A}, T_{vj}=175$	-	2.3	-	V

Dynamic characteristics

C_{ies}	Input capacitance	$V_{CE}=30\text{V}$ $V_{GE}=0\text{V}$ $f=1\text{MHz}$	-	4290	-	pF
C_{oes}	Output capacitance		-	195	-	pF
C_{res}	Reverse transfer capacitance		-	20	-	pF
Q_g	Total gate charge	$V_{CC}=520\text{V}$ $V_{GE}=15\text{V}$ $I_C=75\text{A}$	-	130	-	nC



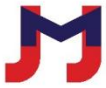

($T_{vj}=25^{\circ}\text{C}$ unless otherwise specified)

V_F	Diode forward voltage	$I_F=75\text{A}$	0.95	1.1	1.25	V
		$I_F=75\text{A}, T_{vj}=175^{\circ}\text{C}$	-	0.95	-	V
t_{rr}	Diode reverse recovery time	$V_R=400\text{V}$ $I_F=75\text{A}$ $di_F/dt=-450\text{A/ s}$	-	610	-	ns
I_{rrm}	Diode peak reverse recovery current		-	15	-	A
Q_{rr}	Diode reverse recovery charge		-	4950	-	nC
t_{rr}	Diode reverse recovery time	$V_R=400\text{V}$ $I_F=75\text{A}$ $di_F/dt=-450\text{A/ s}$ $T_{vj}=175^{\circ}\text{C}$	-	745	-	ns
I_{rrm}	Diode peak reverse recovery current		-	24	-	A
Q_{rr}	Diode reverse recovery charge		-	14500	-	nC

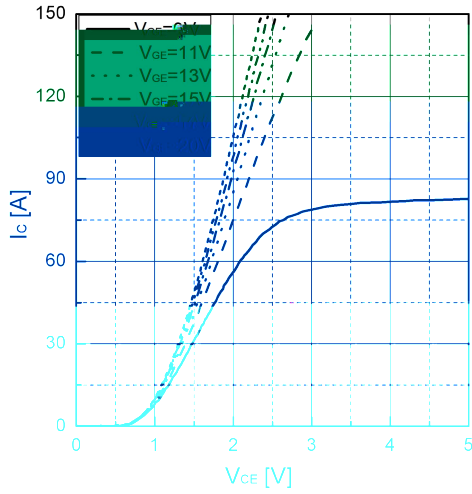

Fig 1. Typical output characteristic ($T_{vj}=25^{\circ}\text{C}$)

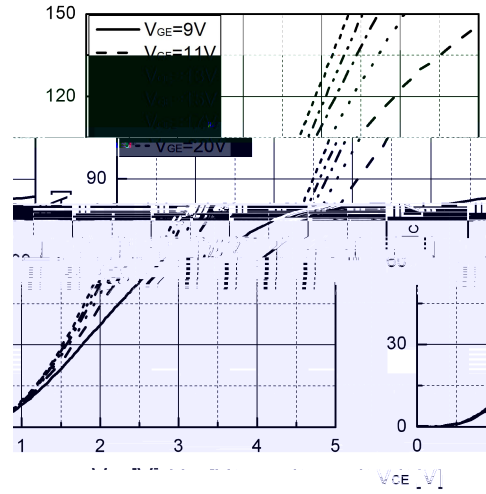

Fig 2. Typical output characteristic ($T_{vj}=175^{\circ}\text{C}$)

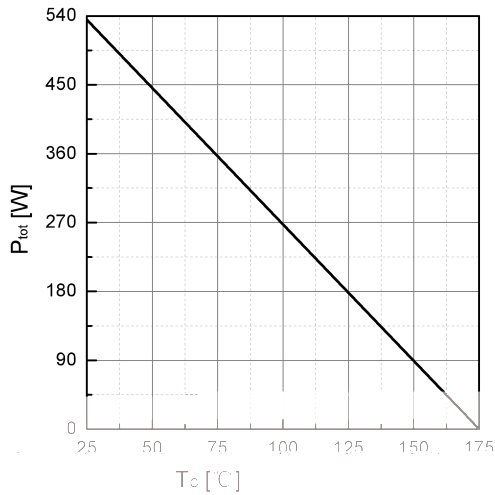

Fig 3. Power dissipation as a function of T_c

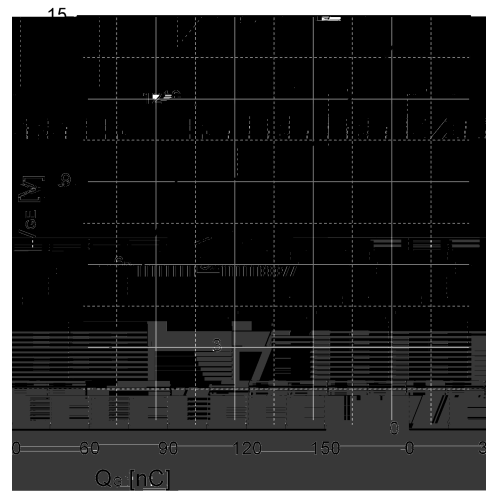

Fig 4. Typical Gate charge

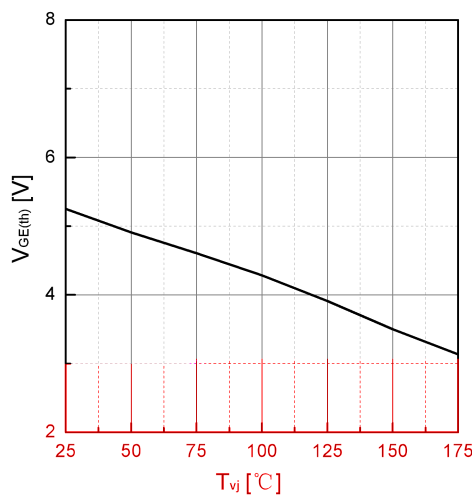

Fig 5. Typical $V_{GE(th)}$ as a function of T_{vj}
($I_C=1\text{mA}$)

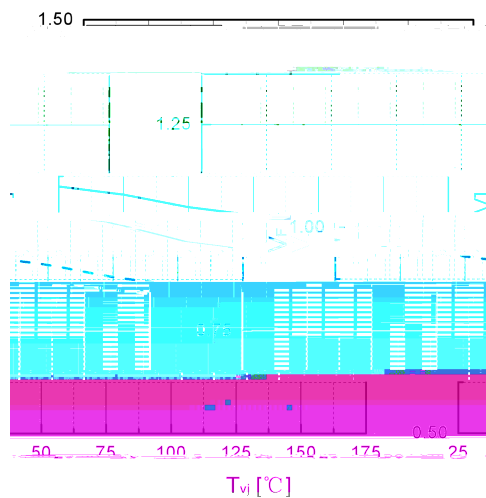

Fig 6. Typical V_F as a function of T_{vj}

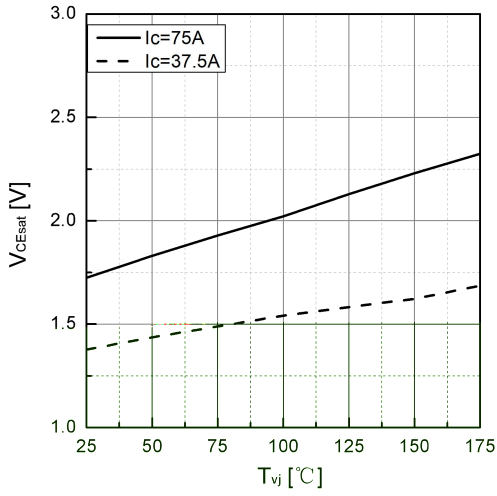

Fig 7. Typical V_{CEsat} as a function of T_{vj}

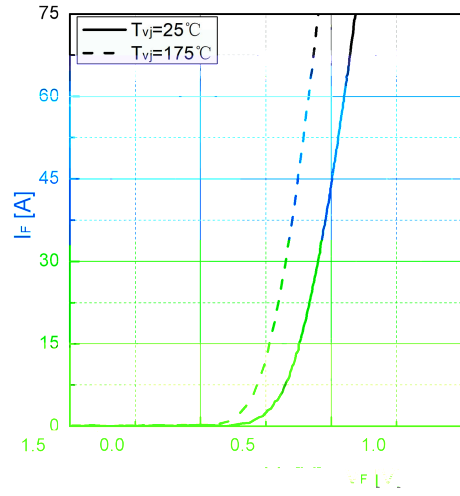

Fig 8. Typical I_F as a function of V_F

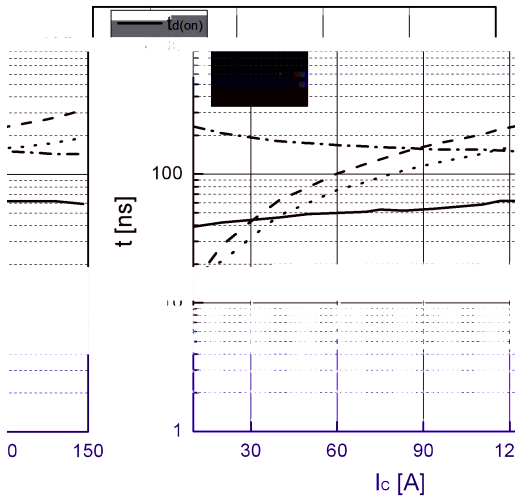

Fig 9. Typical switching time as a function of I_c

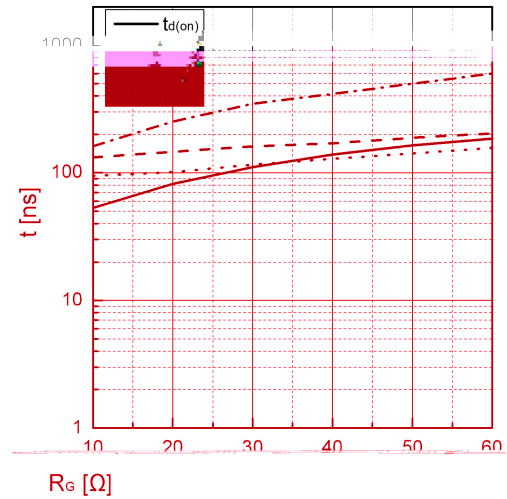

Fig 10. Typical switching times as a function of R_G

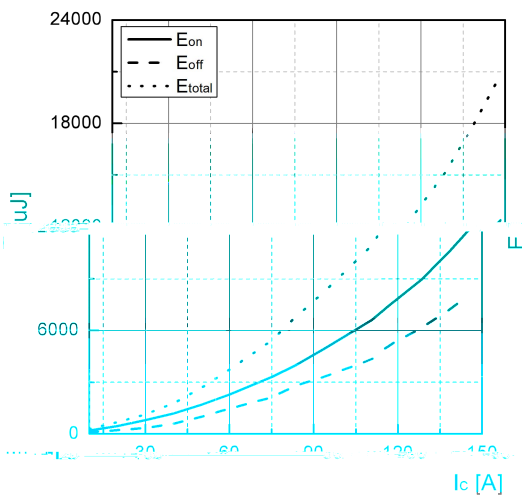

Fig 11. Typical switching energy losses as a function of I_c

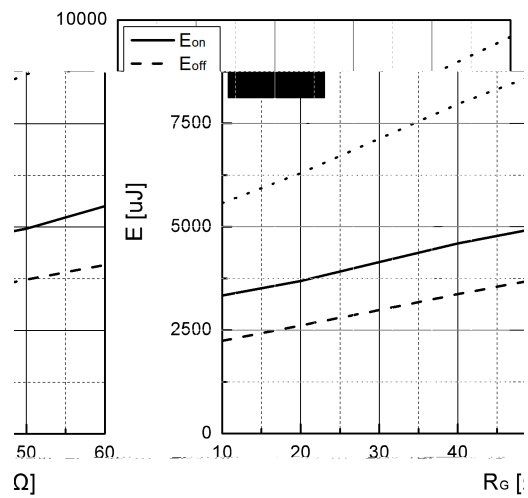

Fig 12. Typical switching energy losses as a function of R_G

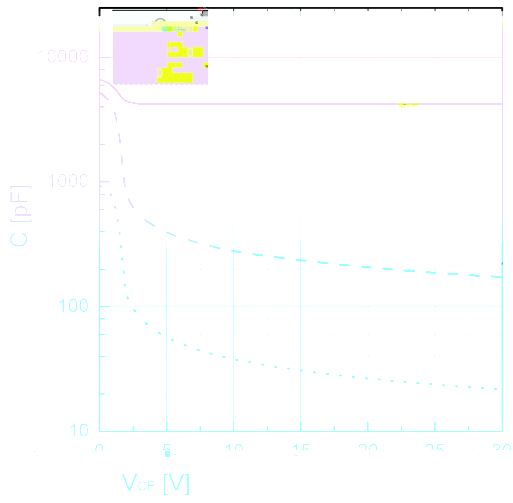

Fig 13. Typical capacitance as a function of V_{CE}
($f=1\text{MHz}$, $V_{GE}=0\text{V}$)

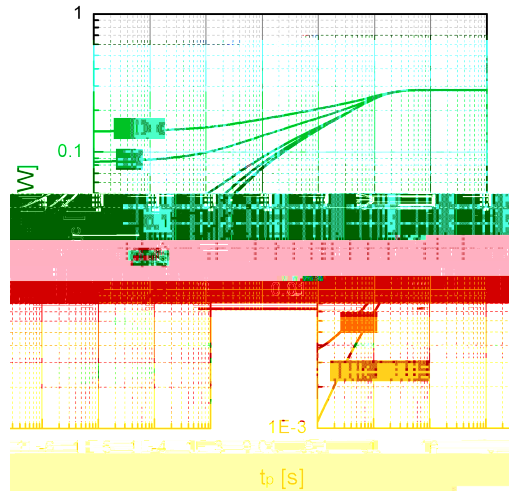
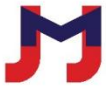
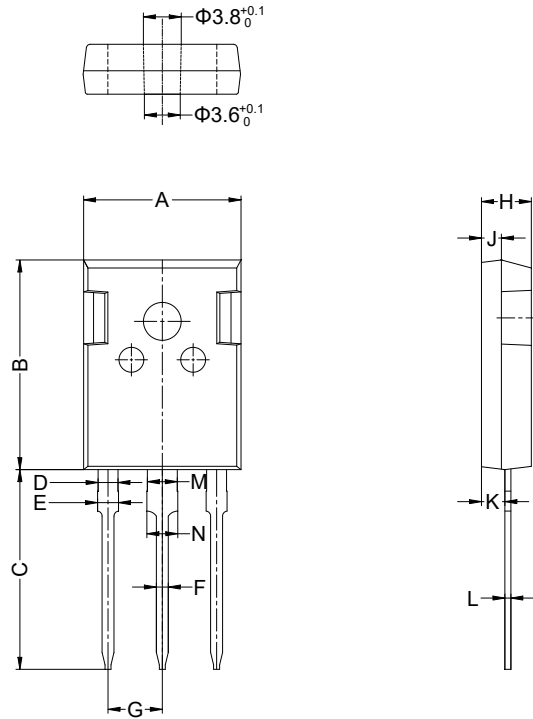

Fig 14. Transient thermal impedance of IGBT



TO-247



Ref.	Dimensions					
	Millimeters			Inches		
	Min.	Typ.	Max.	Min.	Typ.	Max.
A	15.50	15.80	16.10	0.610	0.622	0.634
B	20.80	21.00	21.20	0.819	0.827	0.835
C	19.70	20.00	20.30	0.776	0.787	0.799
D	1.80	2.00	2.20	0.071	0.079	0.087
E	1.90	2.10	2.30	0.075	0.083	0.091
F	1.00	1.20	1.40	0.039	0.047	0.055
G	5.25	-	5.65	0.207	-	0.222
H	4.80	5.00	5.20	0.189	0.197	0.205
J	1.90	2.00	2.10	0.075	0.079	0.083
K	2.20	2.35	2.50	0.087	0.093	0.098
L	0.41	0.60	0.79	0.016	0.024	0.031
M	2.80	3.00	3.20	0.110	0.118	0.126
N	2.90	3.10	3.30	0.114	0.122	0.130



Date	Revision	Changes
2025-7-8	Rev 1.0	Release of the Datasheet
2025-9-5	Rev 1.1	

PLEASE NOTE - Jiangsu JieJie Microelectronics Co., Ltd ("JJM") reserves the right to amend, correct, modify and enhance the product and/or this document at any time without prior notice. If you intend to purchase this product, please obtain the latest information available before placing your order. The sale of JJM products is governed by JJM's prevailing terms and conditions at the time of purchase and purchasers are solely responsible for the selection and use of the products with no liability on JJM's part to supply application assistance or customization. Purchase of JJM products does not grant the purchaser license, express or implied, to JJM's intellectual property. Any warranties provided with JJM products are null and void upon resale unless accompanied by the information set forth herein in its entirety. The JJM name and logo are registered trademarks of Jiangsu JieJie Microelectronics Co., Ltd. This document supersedes all previous versions. ©2025 JJM - All rights reserved